

AISTech[®]2026

< Premier Sponsor >
THE SYSTEMS GROUP

< Global Sponsors >
SUPERBOOTH

MORGAN

TMEiC
We drive industry



PHOENIX
TECHNOLOGIES S.A.

a PIRSON GROUP company 

Major reduction of BF CO₂ emissions by pushing forward the injection of hydrogen rich auxiliary fuels

Fernand DIDELO



Nicolas MOUSEL



Agenda

- Context
- The concept
- Operation KPI and economics
- Conclusion



THE CONTEXT



Blast furnace decarbonization paths

- **Carbon direct avoidance**
 - Hydrogen usage
 - Top gas recycling
 - Electrification
- **Carbon capture and storage (CCS)**



Tuyere injection – the simplest way

The potential candidates for hydrogen rich auxiliary fuel:

- Diesel
- Natural gas
- Ethanol
- Methanol
- Hydrogen
- Ammonia

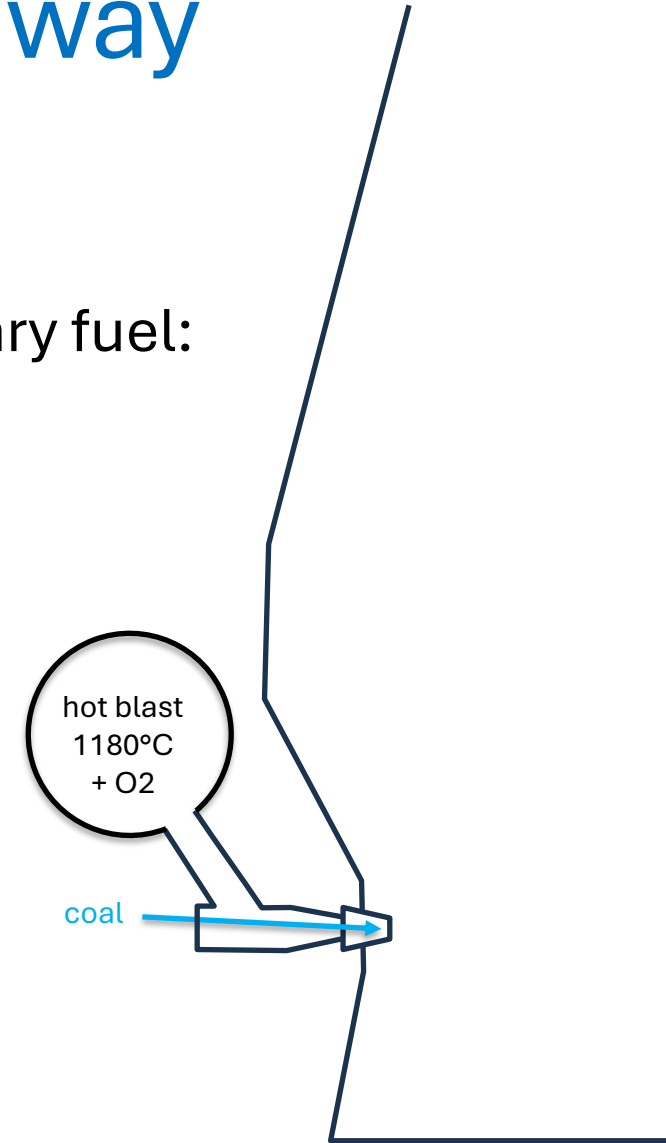

The Adiabatic Flame Temperature Issue

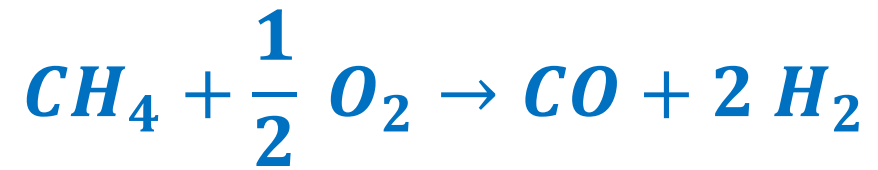

CH ₄	O ₂	RAFT
25°C	25°C	620°C
25°C	1180°C	925°C

Usual RAFT range \approx 1950°C-2200°C

Injectant oxidation energy

injectant	in air		in BF raceway		
		ΔH kJ/mol		ΔH kJ/mol	ΔH kJ/mol_(CO+H ₂)
Carbon	$C + O_2 \rightarrow CO_2$	-393	$C + \frac{1}{2} O_2 \rightarrow CO$	-110	-110
CH₄	$CH_4 + 2 O_2 \rightarrow CO_2 + 2 H_2O$	-802	$CH_4 + \frac{1}{2} O_2 \rightarrow CO + 2 H_2$	-36	-12
H₂	$H_2 + \frac{1}{2} O_2 \rightarrow H_2O$	-242	<i>No reaction</i>	0	0
CO	$CO + \frac{1}{2} O_2 \rightarrow CO_2$	-283	<i>No reaction</i>	0	0

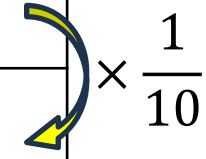
 $\times \frac{1}{10}$

Energy delivered at tuyere

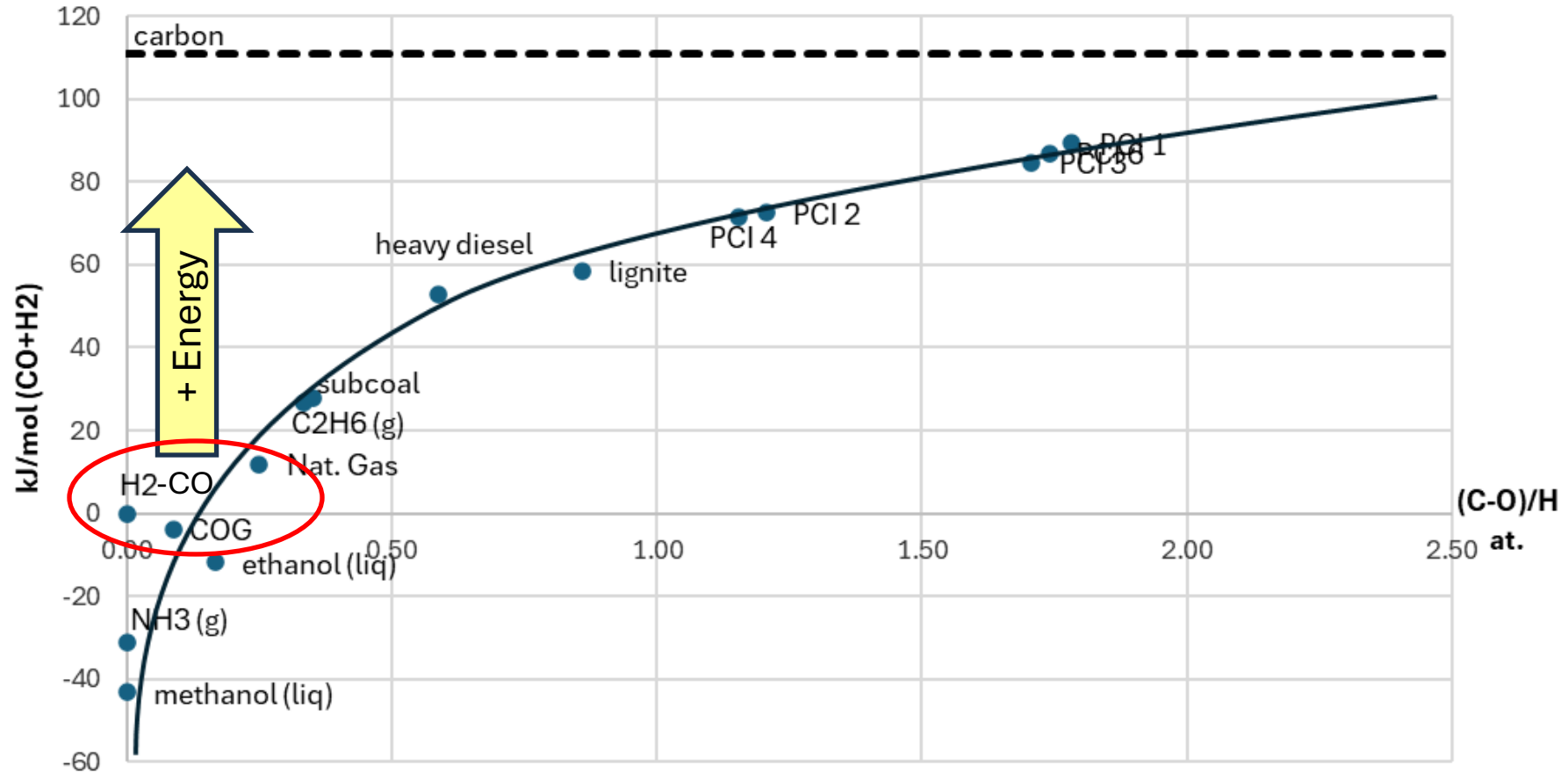

THE CONCEPT



LeanCarb™ concept

project:

- To inject high volumes of lean carbon auxiliary fuels at BF tuyeres and to keep the energy input at tuyere constant by controlling the hot blast temperature with a plasma torch.
- Hot blast temperature target: 2000°C and more

constrains:

- must be safe
- must be reversible
- must be a retrofit on existing BF
- no major stoppage for implementation
- CO₂ abatement cost must be lower than the certificate price
- no significant effect on BF operation

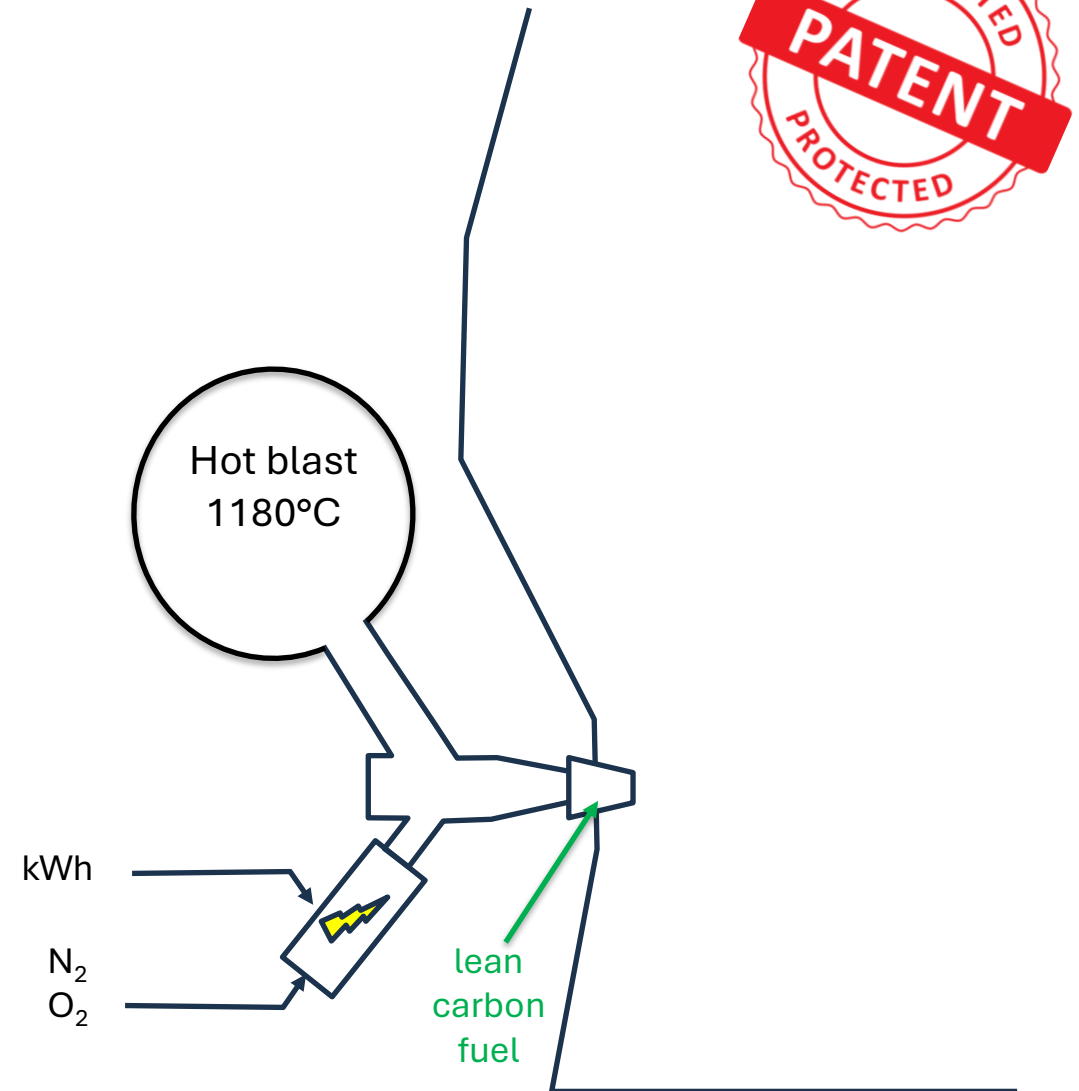

AISTech2026

Premier Sponsor

Global Sponsors



SUPERBOOTH



TMEiC



PHOENIX
TECHNOLOGIES S.A.

Specially designed tuyere stocks for plasma torches



4 MW plasma torch

Static Temperature [C]

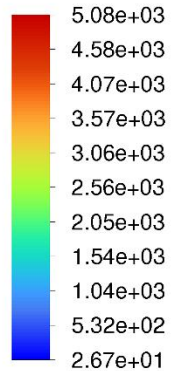

pathlines-1

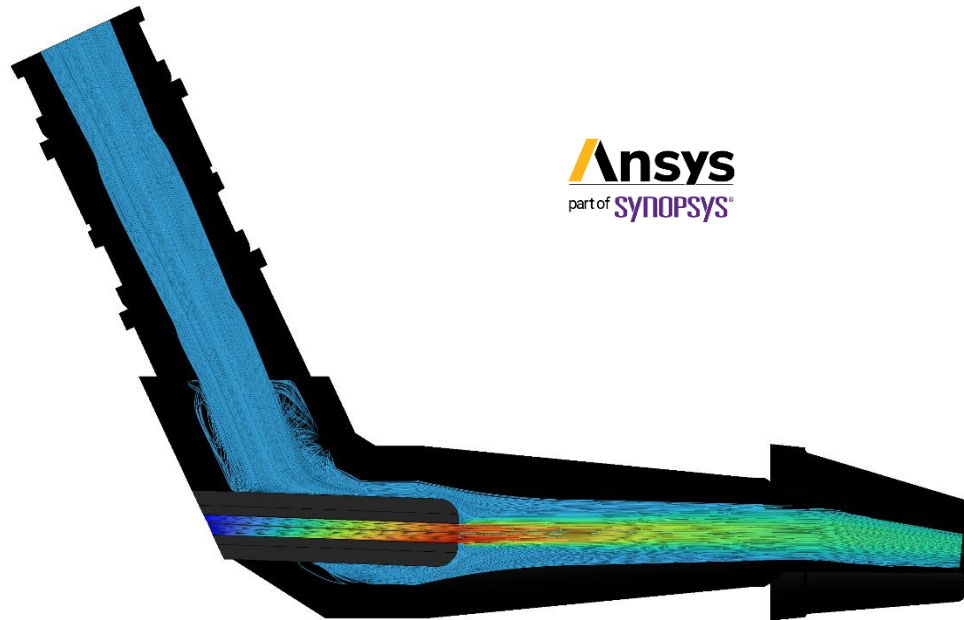

Typical layout

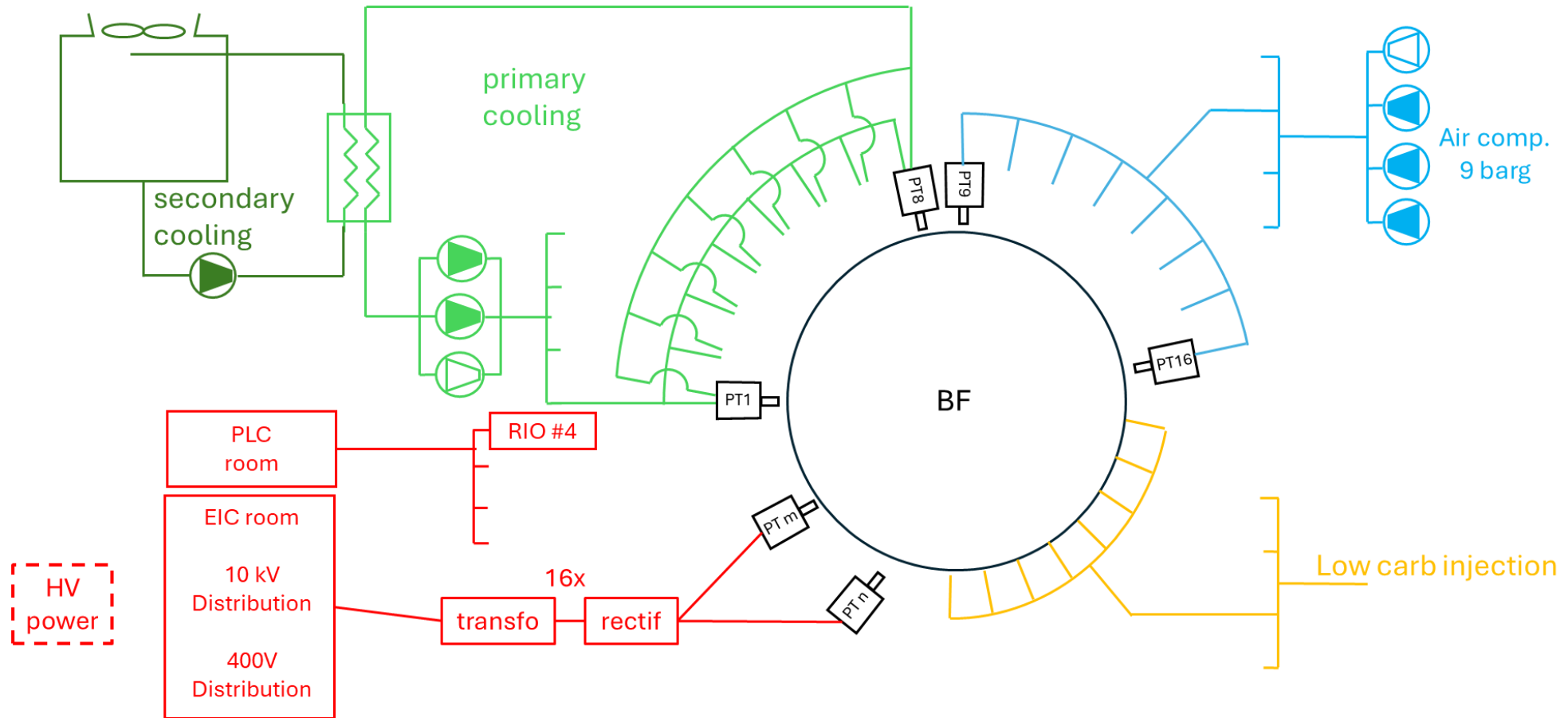

OPERATION KPI AND ECONOMICS



Case: Natural Gas

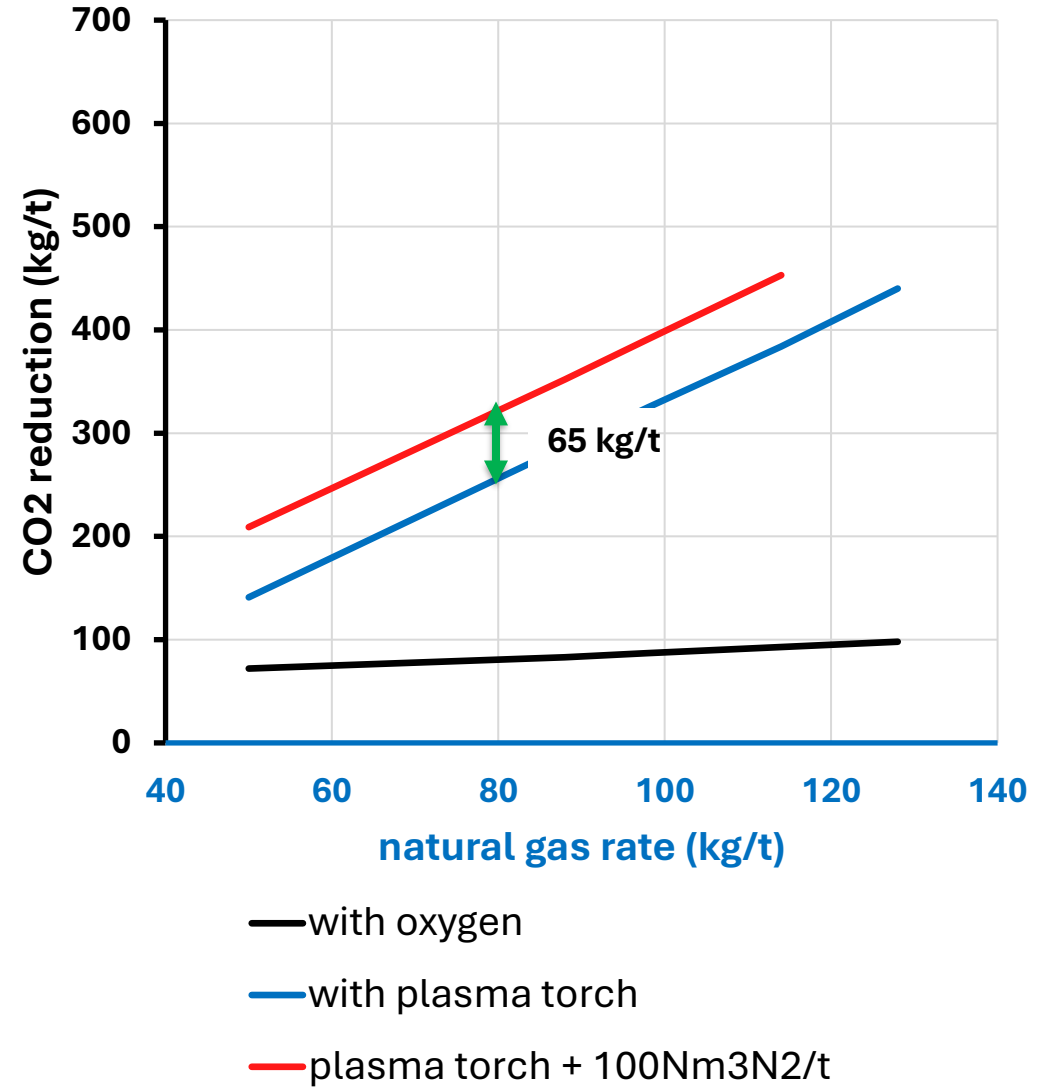
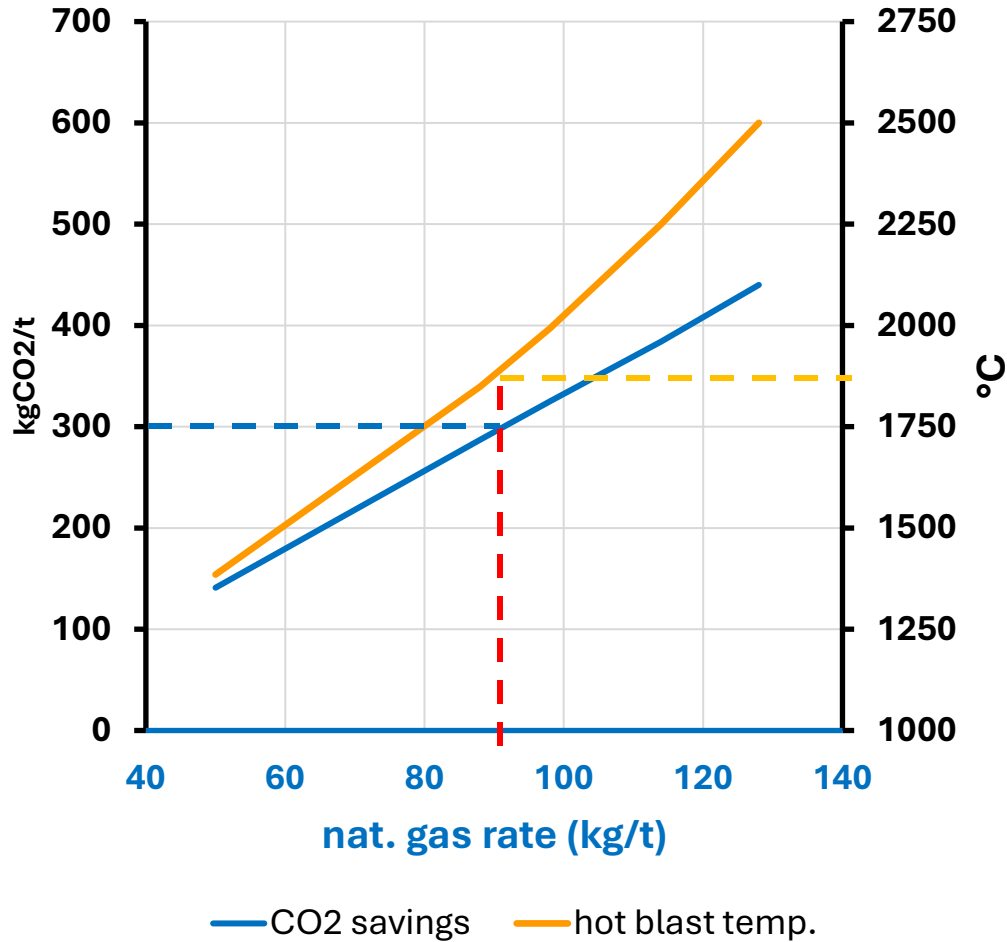

Case: Hydrogen and Coke Oven Gas

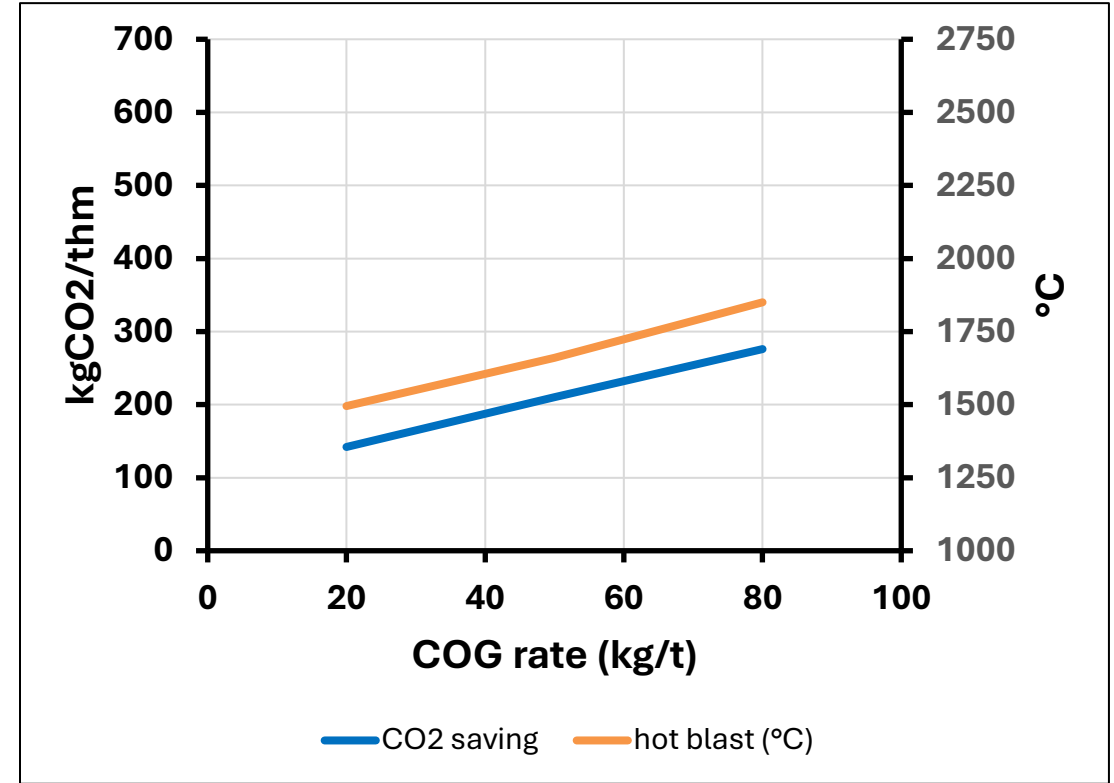
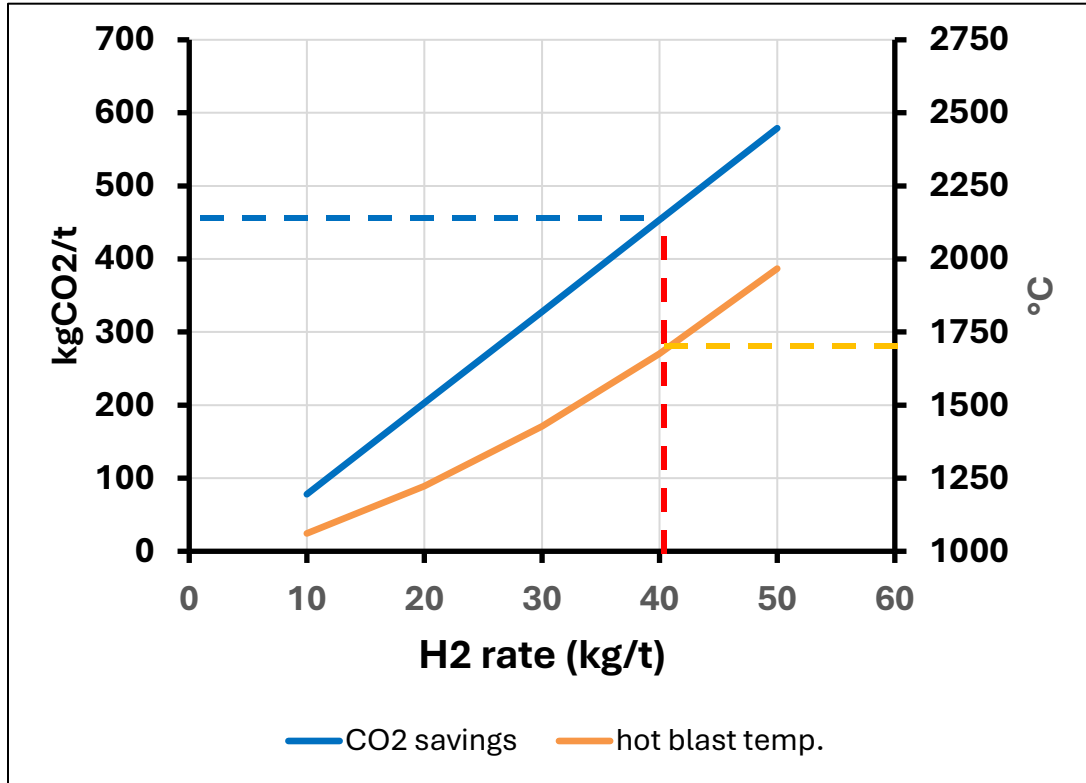

Electric Power – day ahead market

price distribution

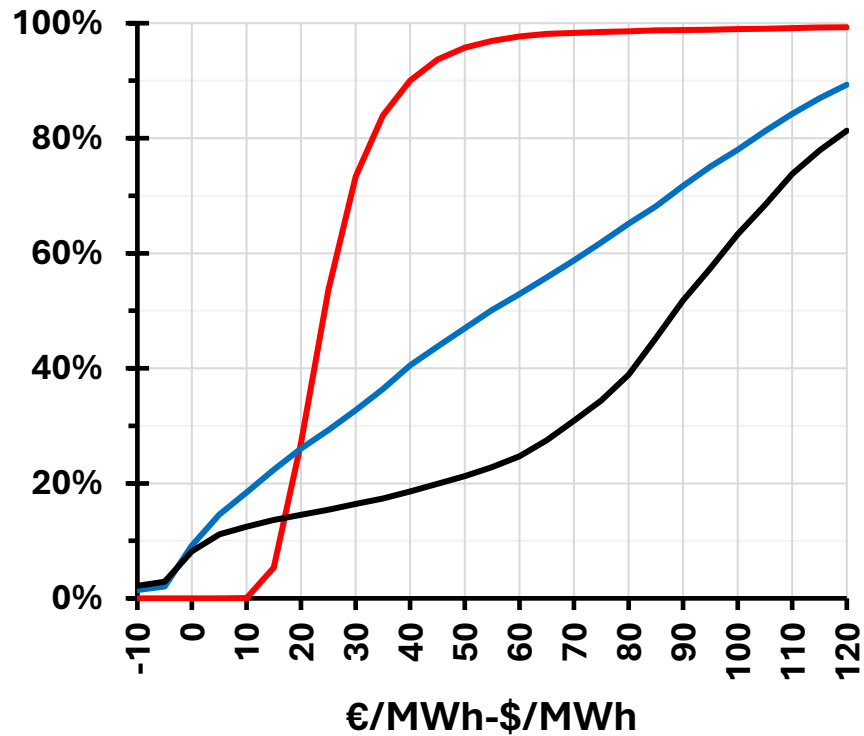

- US-MISO
- FRANCE
- GERMANY

Germany – Electric power price
2025 hourly data

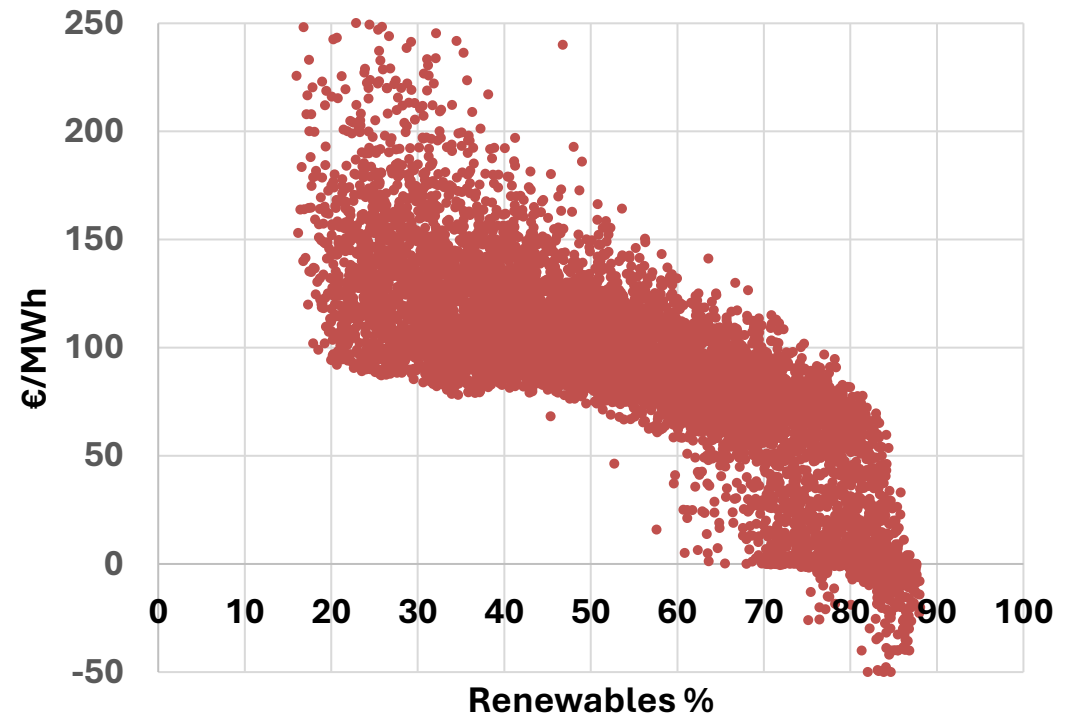

Operation data



	Ref: PCI		Ref: Nat. Gas	
	conventional	LeanCarb™	conventional	LeanCarb™
Coke (kg/t)	323		378	270
Injectant (kg/t)	PCI: 180	NG: 82	NG: 98	NG: 130
Oxygen (%)	24.8	18.7*	29.5	23
Elec power (kWh/t)	-	468	-	495
RAFT (°C)	2150	2150	1994	2002
Top Gas (°C)	150	125	105	150
CO2 (kg/t)	1540	1237	1453	1203

* 100 Nm³N₂/thm

-20%

High flexibility for operating with cheap renewable electricity

-17%

Highly efficient operation on long run



CO2 abatement cost (€/t) for reference PCI operation

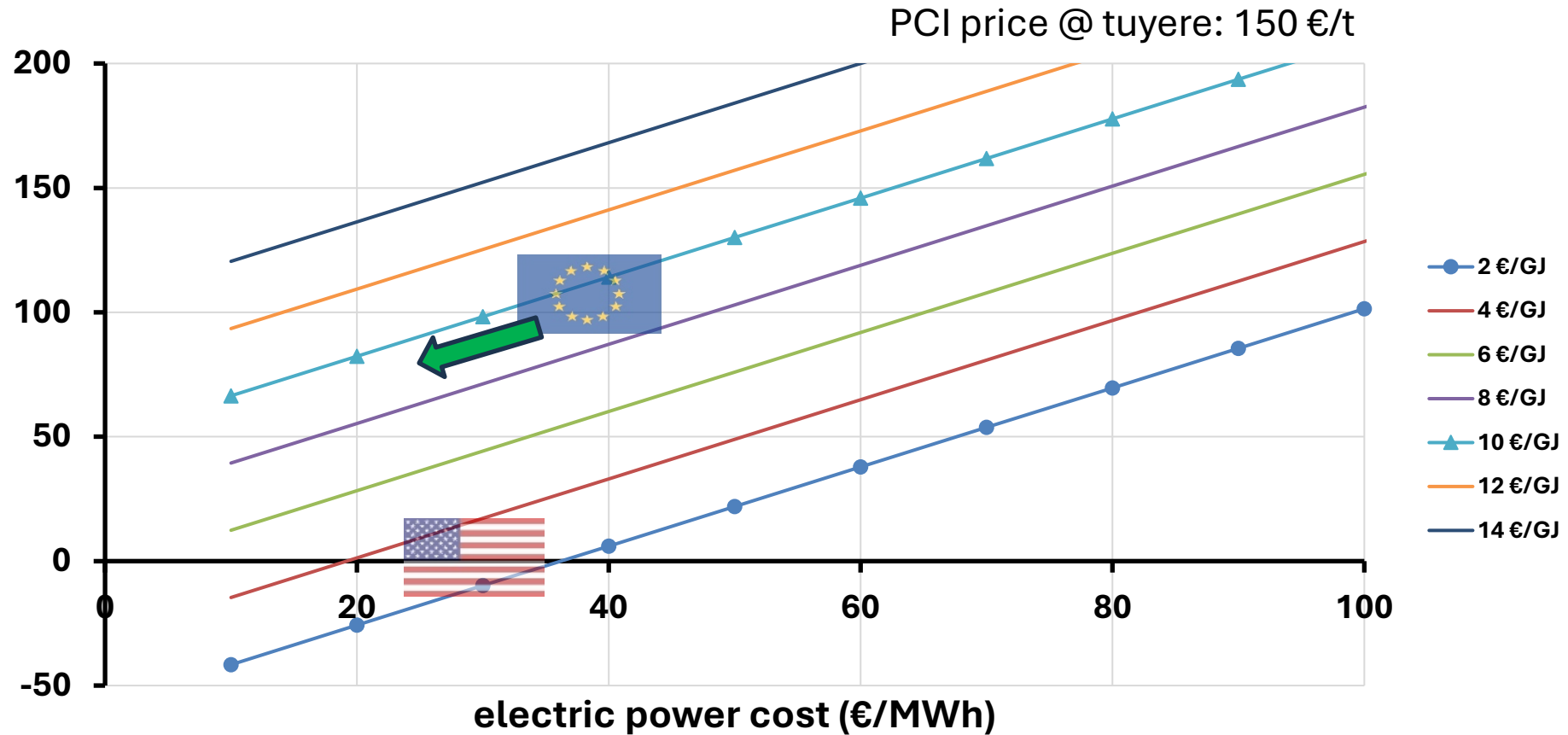

CO2 abatement cost (€/t) for reference NG operation

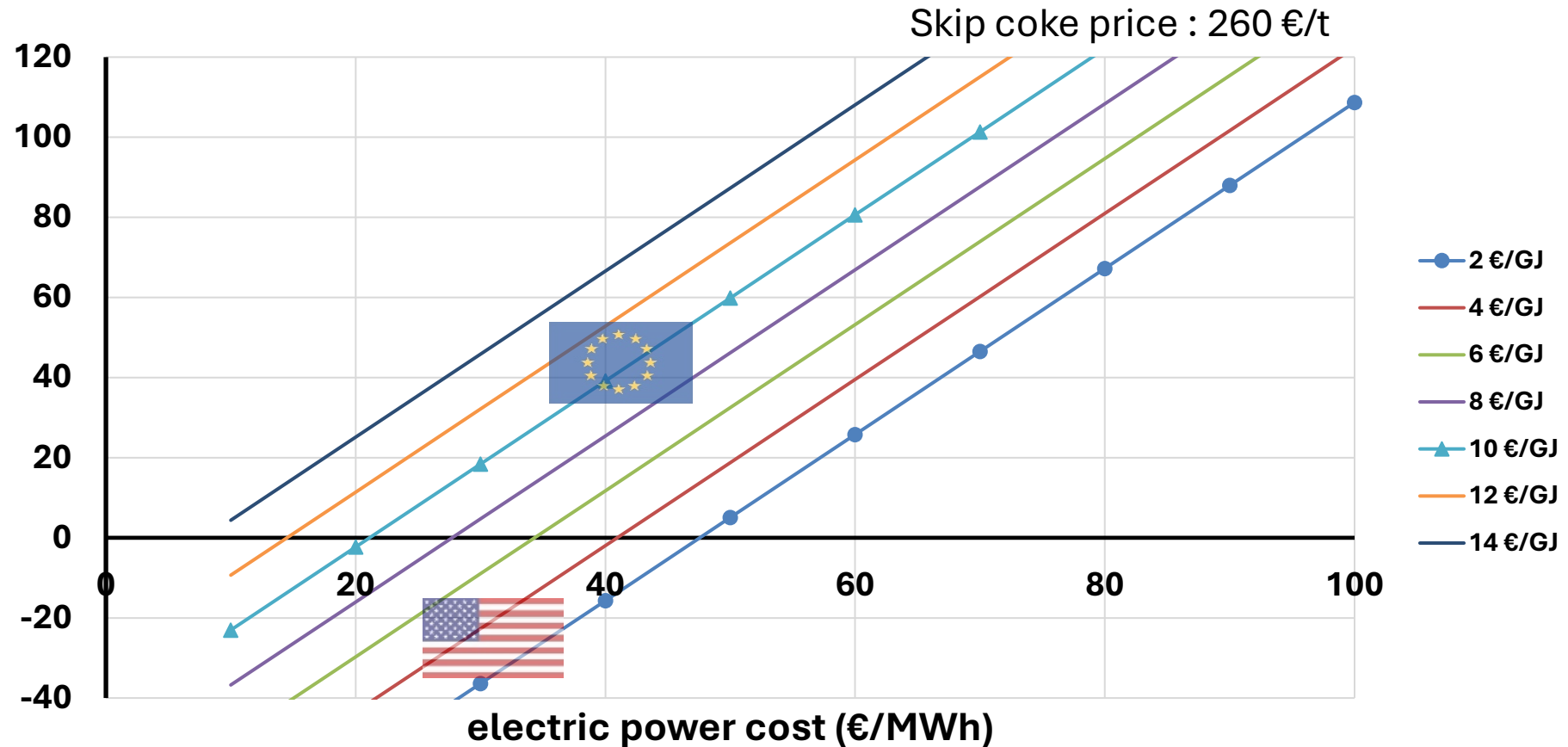

Conclusion

- Hydrogen rich injectant and plasma torch = efficient combination for reducing CO₂ emissions at BF
- The concept, designed for almost all BFs, quick implementation, reversible, versatile and flexible.
- Potential CO₂ reduction: 250-300 kg/thm
- Strongly competitive CO₂ abatement cost



THANK YOU FOR YOUR ATTENTION

fernand.didelon@phoenix-technologies.eu



www.phoenix-technologies.eu